

RACK AND PINION

ACTUATORS AND ACCESSORIES

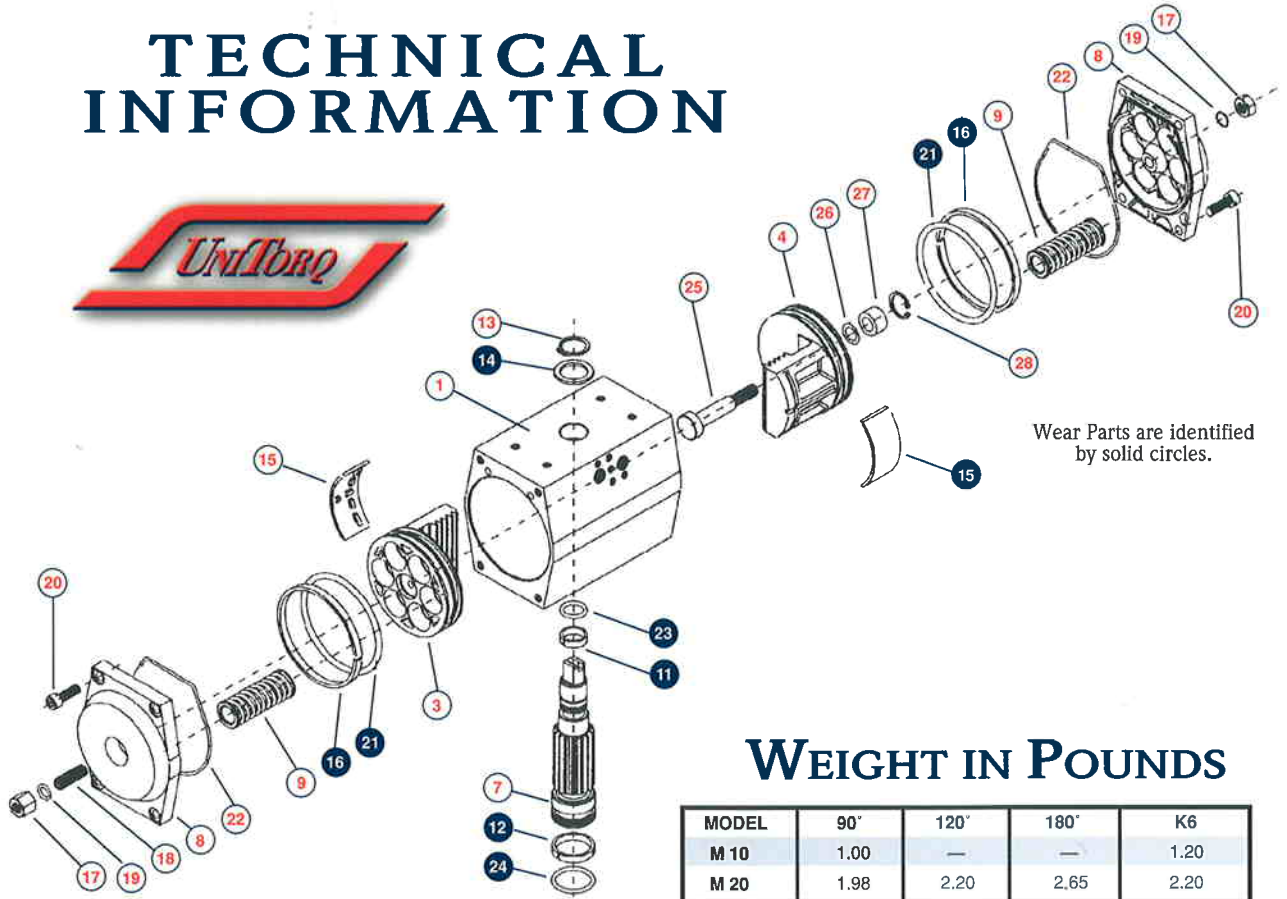

TECHNICAL INFORMATION



M-SERIES MATERIALS

POS.	QTY.	DESCRIPTION	MATERIAL
1	1	BODY	ANODIZED ALUMINUM POLYESTER EPOXY COATING
3	1	PISTON STD**	DIE CAST ALUMINUM
4	1	PISTON DLS**	DIE CAST ALUMINUM
7	1	PINION	E.N.P. ASTM B656 STEEL
8	2	END CAP**	EPOXY COATED ALUMINUM
9	MAX 12	SPRING CARTRIDGE	EPOXY COATED STEEL DELTRIN / BRASS
11	1	UPPER PINION BEARING	DELTRIN 500
12	1	LOWER PINION BEARING	DELTRIN 500
13	1	CIRCLIP	E.N.P. ASTM B656 STEEL
14	1	PINION WASHER	DELTRIN 500
15	2	PISTON SKATE	DELTRIN 500
16	2	PISTON GUIDE RING	DELTRIN 500
17	2	SEALING NUT	304 Stainless Steel
18	2	TRAVEL STOP	304 Stainless Steel
19	2	TRAVEL STOP O-RING	BUNA N
20	8	END CAP SCREW	304 Stainless Steel
21	2	PISTON O-RING	BUNA N
22	2	END CAP O-RING	BUNA N
23	1	UPPER PINION O-RING	BUNA N
24	1	LOWER PINION O-RING	BUNA N
25	1	DLS STOP BOLT	304 STAINLESS STEEL
26	1	DLS STOP BOLT O RING	VITON
27	1	DLS STOP BOLT BEARING	TEFLON
28	1	DLS STOP BOLT CIRCLIP	E.N.P. ASTM B656 STEEL

** M10 - M20 utilize polyrlamide materials

WEIGHT IN POUNDS

MODEL	90°	120°	180°	K6
M 10	1.00	—	—	1.20
M 20	1.98	2.20	2.65	2.20
M 30	2.98	3.26	3.97	3.42
M 52	4.30	4.74	5.95	5.07
M 73	5.51	5.95	7.94	6.39
M 103	7.39	8.16	11.25	8.38
M 148	10.58	11.47	13.56	12.79
M 222	14.99	16.90	20.68	17.86
M 295	18.74	20.73	26.02	22.49
M 470	31.00	—	—	39.80
M 586	34.40	39.69	55.79	42.78
M 900	61.50	—	—	83.10
M 1213	68.80	81.14	106.94	86.66
M 2366	132.32	146.63	173.60	180.81
M 2958	160.97	177.60	—	209.48
M 3720	205.00	—	—	267.00

AIR CONSUMPTION

CUBIC INCHES PER CYCLE (Open/Close)

MODEL	90°	120°	180°	K6
M 10	12.8	—	—	6.7
M 20	15.3	17.1	28.1	7.3
M 30	22.0	24.4	41.5	9.2
M 52	36.6	42.7	68.3	15.3
M 73	52.5	61.0	99.5	22.0
M 103	67.1	82.4	131.2	27.5
M 148	112.9	137.3	189.2	41.5
M 222	152.6	176.9	341.7	67.1
M 295	218.5	241.0	415.0	86.7
M 470	335.6	—	—	174.5
M 586	416.2	476.0	790.2	174.5
M 900	762.8	—	—	396.7
M 1213	872.6	1013.0	1293.7	360.0
M 2366	1586.6	1861.2	2471.5	701.8
M 2958	1922.2	2288.4	—	1037.4
M 3720	2955.0	—	—	1594.0

Unitorq Pneumatic Actuator Torque Chart

The Following Torque Values Are in IN.-LB. And Represent Air Stroke For The Spring Return Unit.

PSI	40 60 80 100 120					K#	ALL		40		60		80		100		120	
	DOUBLE ACTING TORQUE in lbs.						SPRING		AIR		AIR		AIR		AIR		AIR	
	Start	End	Start	End	Start		End	Start	End	Start	End	Start	End	Start	End	Start	End	Start
M10	50	75	100	125	150	2	56	38	—	11	18	35	42	60	67	85	92	110
	—	—	—	—	—	3	83	57	—	—	—	16	15	40	40	65	65	90
	102	152	203	254	305	2	56	38	44	62	94	112	144	162	194	212	244	262
M20	—	—	—	—	—	3	83	57	15	42	65	92	115	142	165	192	215	242
	—	—	—	—	—	4	111	76	—	22	36	72	66	122	136	172	186	222
	—	—	—	—	—	5	139	95	—	2	6	52	56	102	106	152	156	202
M30	151	227	302	378	453	2	80	56	69	93	144	168	218	242	293	317	367	391
	—	—	—	—	—	3	119	83	30	66	104	140	179	215	253	289	328	364
	—	—	—	—	—	4	159	111	—	38	64	112	139	187	213	261	288	336
M52	—	—	—	—	—	5	199	139	—	10	24	84	99	159	173	233	248	308
	—	—	—	—	—	6	239	167	—	—	—	56	59	131	133	206	208	280
	263	395	526	658	789	2	154	104	105	155	235	285	365	415	494	545	624	675
M73	—	—	—	—	—	3	232	156	28	103	158	233	287	363	417	493	547	623
	—	—	—	—	—	4	309	208	—	51	80	181	210	311	340	441	469	570
	—	—	—	—	—	5	386	260	—	—	3	129	132	259	262	388	392	518
M103	—	—	—	—	—	6	463	312	—	—	—	76	55	206	185	336	314	466
	367	551	734	918	1101	2	199	127	163	235	344	417	525	598	706	779	887	960
	—	—	—	—	—	3	299	190	63	172	244	353	426	534	607	715	788	896
M148	—	—	—	—	—	4	398	253	—	108	145	290	326	471	507	652	688	833
	—	—	—	—	—	5	498	317	—	45	45	226	226	407	407	588	588	769
	—	—	—	—	—	6	597	380	—	—	—	162	126	343	307	524	488	706
M222	516	774	1032	1290	1548	2	267	189	241	318	495	572	749	826	1002	1080	1256	1334
	—	—	—	—	—	3	400	284	107	223	361	477	615	731	869	985	1123	1239
	—	—	—	—	—	4	533	379	—	128	227	382	481	638	735	890	989	1144
M295	—	—	—	—	—	5	667	473	—	33	93	287	347	541	601	795	855	1049
	—	—	—	—	—	6	800	568	—	—	—	192	213	446	467	700	721	954
	740	1109	1479	1849	2219	2	407	260	321	468	695	832	1049	1196	1413	1560	1777	1924
M470	—	—	—	—	—	3	611	391	117	337	481	701	845	1065	1209	1429	1573	1793
	—	—	—	—	—	4	814	521	—	207	277	571	641	935	1005	1299	1369	1663
	—	—	—	—	—	5	1018	651	—	76	73	440	437	804	801	1168	1165	1532
M586	—	—	—	—	—	6	1221	781	—	—	—	309	232	673	596	1037	960	1401
	1109	1664	2218	2773	3327	2	550	400	489	645	1018	1174	1548	1704	2077	2233	2607	2763
	—	—	—	—	—	3	826	600	188	426	718	956	1247	1485	1777	2015	2307	2544
M900	—	—	—	—	—	4	1101	800	—	200	407	729	936	1259	1466	1789	1995	2318
	—	—	—	—	—	5	1376	1000	—	—	84	495	614	1025	1144	1554	1673	2084
	—	—	—	—	—	6	1651	1200	—	—	—	253	261	783	810	1312	1340	1842
M1213	1479	2219	2958	3698	4437	2	814	516	641	939	1369	1667	2097	2395	2825	3123	3552	3850
	—	—	—	—	—	3	1222	775	234	681	962	1409	1689	2137	2417	2864	3145	3592
	—	—	—	—	—	4	1629	1033	—	423	554	1150	1282	1878	2010	2606	2738	3334
M1824	—	—	—	—	—	5	2036	1291	—	164	147	892	874	1620	1602	2348	2330	3075
	—	—	—	—	—	6	2443	1549	—	—	—	634	467	1361	1195	2089	1922	2817
	2071	3106	4142	5177	6213	2	1133	681	938	1390	1974	2425	3009	3461	4045	4496	5080	5532
M2436	—	—	—	—	—	3	1699	1022	371	1049	1407	2084	2443	3120	3478	4155	4514	5191
	—	—	—	—	—	4	2266	1363	—	708	840	1743	1876	2779	2911	3841	3947	4850
	—	—	—	—	—	5	2832	1704	—	367	273	1402	1309	2438	2344	3473	3380	4509
M3048	—	—	—	—	—	6	3398	2044	—	26	—	1061	742	2097	1777	3132	2813	4168
	2933	4399	5865	7331	8796	2	1542	1052	1344	1834	2787	3277	4320	4720	5673	6163	7117	7606
	—	—	—	—	—	3	2312	1578	573	1308	2016	2751	3459	4194	4902	5637	6345	7080
M3660	—	—	—	—	—	4	3083	2104	—	781	1245	2224	2888	3667	4131	5111	5574	6554
	—	—	—	—	—	5	3854	2630	—	255	473	1698	1916	3141	3359	4584	4802	6027
	—	—	—	—	—	6	4625	3196	—	—	—	1171	1145	2614	2588	4058	4031	5501
M4272	4550	6825	9100	11375	13650	2	2251	1619	2227	2859	4466	5098	6705	7337	8944	9576	11183	11815
	—	—	—	—	—	3	3376	2428	1101	2049	3340	4288	5579	6527	7818	8766	10057	11005
	—	—	—	—	—	4	4501	3238	—	1239	2214	3478	4453	5717	6692	7956	8931	10195
M4884	—	—	—	—	—	5	5627	4047	—	429	1088	2669	3327	4907	5566	7146	7805	9385
	—	—	—	—	—	6	6752	4856	—	—	—	1858	2200	4097	4439	6336	6678	8575
	6066	9099	12132	15165	18198	2	3000	2159	2969	3811	5954	6796	8939	9781	11924	12766	14910	15751
M5496	—	—	—	—	—	3	4501	3238	1468	2731	4453	5716	7438	8701	10424	11686	13409	14672
	—	—	—	—	—	4	6001	4317	—	1651	2952	4636	5937	7621	8922	10606	11907	13591
	—	—	—	—	—	5	7501	5397	—	571	1451	3556	4436	6541	7421	9526	10406	12511
M6108	—	—	—	—	—	6	9001	6476	—	—	—	2475	2934	5460	5919	8446	8904	11431
	11833	17749	23665	29581	35498	2	6832	4573	4812	7072	10635	12895	16457	18718	22280	24540	28103	30363
	—	—	—	—	—	3	10249	6859	1394	4785	7217	10607	13040	16430	18862	22253	24685	28076
M6720	—	—	—	—	—	4	13665	9145	—	2497	3798	8319	9621	14142	15444	19965	21267	25788
	—	—	—	—	—	5	17081	11432	—	208	379	6031	6202	11854	12025	17677	17847	23499
	—	—	—	—	—	6	20497	13718	—	—	—	3742	2782	9565	8605	15388	14427	21210
M7332	14790	22186	29581	36976	44371	2	8540	5015	6015	9541	13293	16819	20571	24097	27850	31376	35128	38854
	—	—	—	—	—	3	12811	7523	1742	7832	9021	14310	16299	21589	23577	28867	30856	36145
	—	—	—	—	—	4	17081	10030	—	4523	4748	11801	12026	19079	19304	26358	26583	33636
M7944	—	—	—	—	—	5	21351	12538	—	2013	474	9291	7752	16570	15030	23848	22309	31125
	—	—	—	—	—	6	25621	15045	—	—								

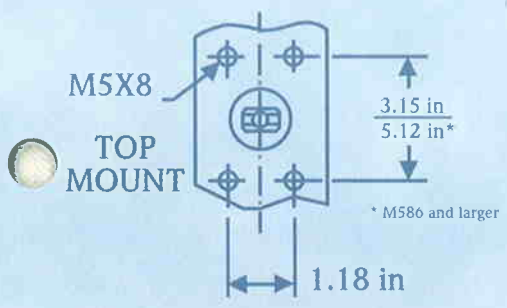

BOTTOM VIEW

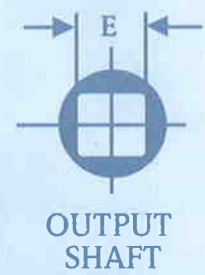
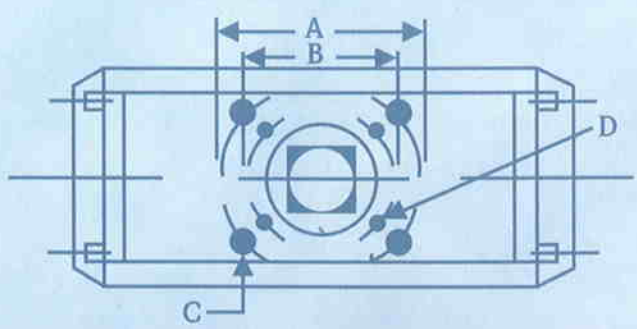

Model	A	FO	B	FO	C*	D*	E	F	G	H	I	L	L1*	M	N	P	R	S	W
M 10	1.65	F04	1.42	F03	#10 - 32	#10 - 32	9 or 11MM	0.55	2.02	3.55	0.35	4.68	—	0.48	—	2.55	1/4	.94	2.09
M 20	1.97	F05	1.42	F03	1/4 - 20	#10 - 32	14MM	0.71	1.97	3.82	0.39	5.00	7.52	0.47	0.79	2.91	1/4	.94	2.32
M 30	2.76	F07	1.97	F05	5/16 - 18	1/4 - 20	14MM	0.71	2.36	4.37	0.39	5.51	7.99	0.47	0.79	3.46	1/4	.94	2.76
M 52	2.76	F07	1.97	F05	5/16 - 18	1/4 - 20	17MM	0.75	2.56	4.84	0.39	6.34	9.33	0.55	1.02	3.94	1/4	.94	3.27
M 73	2.76	F07	1.97	F05	5/16 - 18	1/4 - 20	17MM	0.75	2.56	4.95	0.39	7.17	10.63	0.55	1.02	4.25	1/4	.94	3.58
M 103	2.76	F07	1.97	F05	5/16 - 18	1/4 - 20	17MM	0.75	2.76	5.55	0.55	8.23	12.20	0.79	1.38	4.61	1/4	.94	3.94
M 148	4.02	F10	2.76	F07	3/8 - 16	5/16 - 18	22MM	0.96	3.54	6.45	0.55	8.74	12.72	0.79	1.97	5.51	1/4	.94	4.72
M 222	4.02	F10	2.76	F07	3/8 - 16	5/16 - 18	22MM	0.96	3.54	6.71	0.79	11.50	16.77	1.10	1.97	5.51	1/4	.94	4.72
M 295	4.02	F10	2.76	F07	3/8 - 16	5/16 - 18	22MM	0.98	4.06	7.51	0.79	11.73	17.64	1.10	1.97	6.30	1/4	.94	5.39
M 470	4.92	F12	4.02	F10	1/2 - 13	3/8 - 16	27MM	1.07	4.33	9.70	0.79	13.27	—	1.10	2.36	7.80	1/4	.94	6.77
M 586	4.92	F12	4.02	F10	1/2 - 13	3/8 - 16	27MM	1.07	4.33	9.70	1.10	14.84	22.24	1.42	2.36	7.80	1/4	.94	6.77
M 900	6.50	F16	4.92	F12	3/4 - 10	1/2 - 13	36MM	1.57	5.31	11.77	1.26	16.54	—	1.42	2.84	10.00	1/4	.94	8.82
M 1213	5.51	F14	—	—	5/8 - 11	—	36MM	1.57	5.31	11.77	1.26	18.19	27.17	1.57	2.95	10.00	1/4	.94	8.82
M 2366	6.50	F16	—	—	3/4 - 10	—	46MM	1.57	6.26	13.77	1.26	23.74	35.63	1.57	3.54	11.89	1/4	.94	10.71
M 2958	6.50	F16	—	—	3/4 - 10	—	46MM	1.53	6.26	13.77	1.26	26.89	—	1.57	3.54	11.89	1/4	.94	10.71
M 3720	6.50	F16	—	—	3/4 - 10	—	46MM	1.61	6.30	15.94	1.26	26.89	—	1.58	2.96	14.17	1/2	1.97	14.17

Top mounting dimensions for accessories to Namur standard. Bottom mounting is to DIN-ISO standards.
 Solenoid mounting to Namur specifications is standard on all units.
 * U.N.C. bolt sizes.
 L1* - 180° end-to-end dimensions

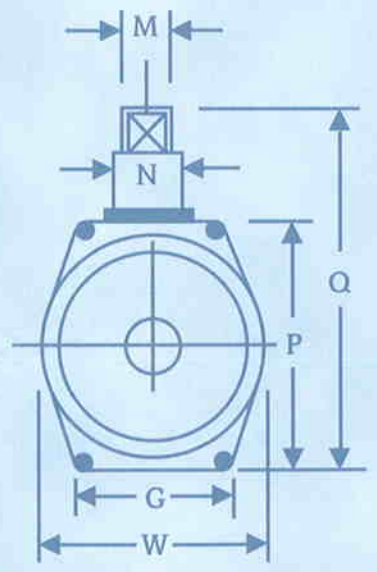
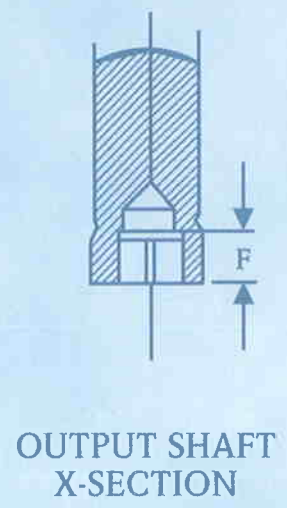
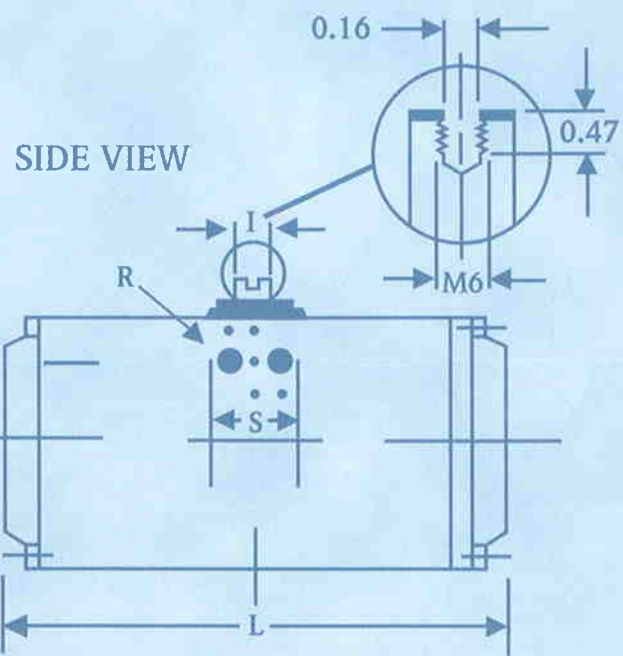

END VIEW

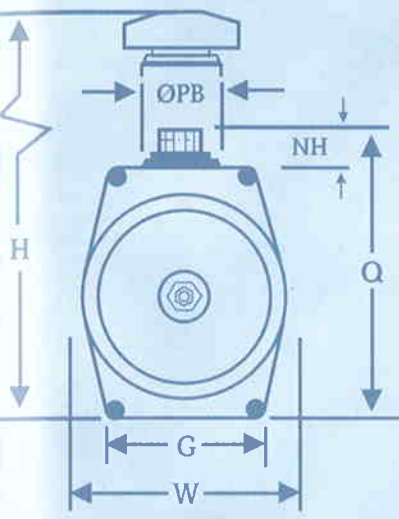
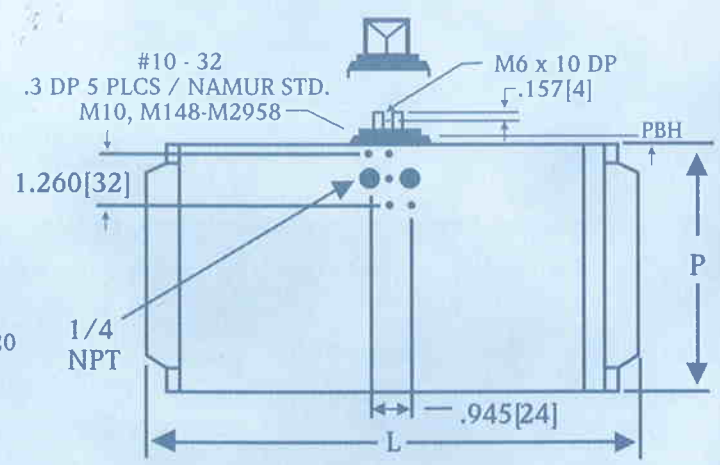
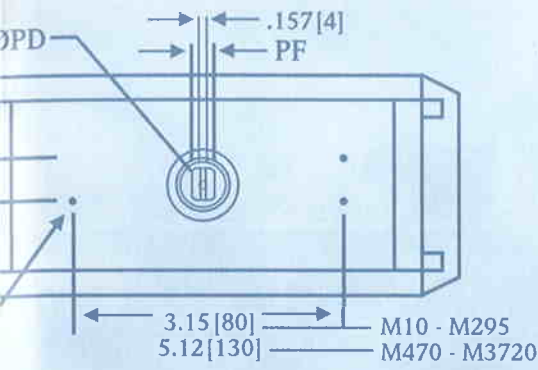

DRIVE DIMENSIONS

SIZE	ISO SQUARE 8 - POINT							
	A mm	A in.	A'	øB	øC	C'	øD	D'
M10	9	0.354	0.41	0.450	0.94	0.08	0.38	1.18
M10	11	0.433	0.41	0.560	0.94	0.08	0.47	1.18
M20	14	0.551	0.61	0.713	0.94	0.08	0.51	1.34
M30	14	0.551	0.61	0.713	1.00	0.08	0.51	1.34
M52	17	0.669	0.63	0.874	1.16	0.08	0.63	1.34
M73	17	0.669	0.63	0.874	1.27	0.08	0.63	1.34
M103	17	0.669	0.63	0.874	1.47	0.08	0.75	1.34
M148	22	0.866	0.83	1.122	1.59	0.10	0.87	1.87
M222	22	0.866	0.83	1.122	2.10	0.10	0.94	1.91
M295	22	0.866	0.83	1.122	2.10	0.12	0.94	1.91
M470	27	1.063	0.83	1.437	2.10	0.12	1.14	1.93
M586	27	1.063	0.83	1.437	2.61	0.12	1.14	1.93
M900	36	1.417	1.26	1.909	2.61	0.16	1.56	2.17
M1213	36	1.417	1.26	1.909	3.12	0.16	1.56	2.17
M2366	46	1.811	1.66	2.441	4.15	0.16	1.97	2.44
M2958	46	1.811	1.66	2.441	5.28	0.16	1.97	2.44
M3270	48	1.811	1.66	2.441	5.28	0.16	1.97	2.44

MOUNTING DIMENSIONS

SIZE	ISO		
	X	Y	Z
M10	F03	—	—
M10	—	F04*	—
M20	F03	F05	—
M30	F05	F07	—
M52	F05	F07	—
M73	F05	F07	—
M103	F05	F07	—
M148	F07	F10	—
M222	F07	F10	—
M295	F07	F10	F12
M470	—	F10	F12
M586	—	F10	F12
M900	—	F12	F16*
M1213	—	—	F14
M2366	—	—	F16
M2958	—	—	F16
M3270	—	—	F16

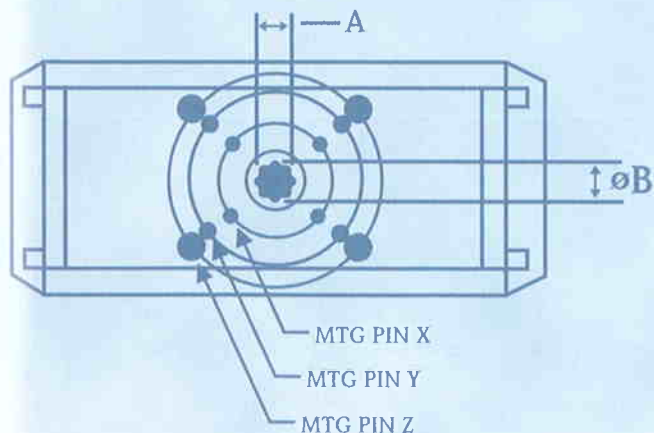
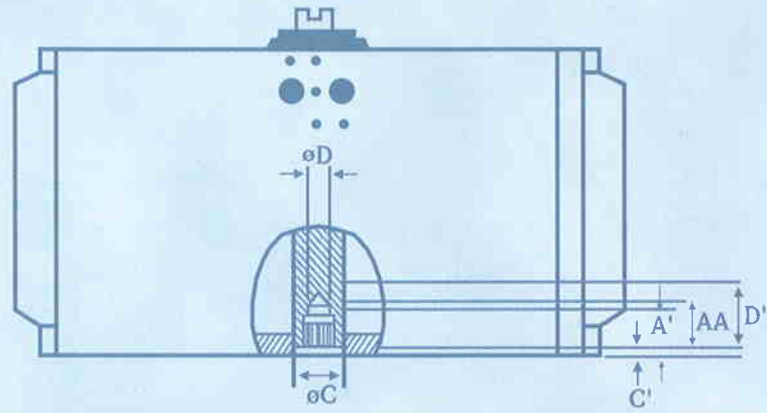

ISO MOUNTING PATTERN TABLE

ISO	øB.C.	øB.C.	THREAD	DP
	in.	mm		
F03	1.417	36	#10 - 32UNC	0.43
F04*	1.654	42	#10 - 32UNC	0.43
F05	1.969	50	1/4 - 20UNC	0.35
F07	2.758	70	5/16 - 18UNC	0.47
F10	4.016	102	3/8 - 16UNC	0.59
F12	4.921	125	1/2 - 13UNC	0.71
F14	5.512	140	5/8 - 11UNC	0.94
F16	6.496	165	3/4 - 10UNC	1.18

* M900 has 5/8" - 11UNC on F16
 * M3720 also includes a 4.59 x 12.87 rectangular pattern
 * Alternate Bottom Plate (M10 Only)

DIMENSIONS



UNITORQ

Established in 1992 in Norcross, Georgia, UniTorq has consistently provided our customers with reliable, affordable actuators and accessories. With a continued focus on the latest trends in technology and manufacturing, we have expanded our product line to include a wider selection of sizes and features to meet the varying needs in today's market. These changing market trends have lead to the introduction of an electric line of actuators in 1999 along with an expanded product line of pneumatic actuators and accessories. At UniTorq, the basic principle is continuous dedication to our customers' needs through the manufacturing and distribution of superior actuation products with an ongoing commitment to dependable service and support.



UNITORQ — HOW TO SPECIFY

Actuator will be a dual rack and pinion design with a one piece electroless nickel plated pinion that is machined a continuous 360 degrees and drive dimensions to ISO 5211 dimensions. The pinion shall have upper and lower Delrin 500 encapsulated bearings. The actuator body shall be of extruded aluminum, hard anodized after machining and then painted with a one part dry powder epoxy polyester paint for additional external protection. End caps shall be aluminum die cast with one part dry powder epoxy polyester for protection. End caps shall be affixed to the body with stainless steel UNC cap screws. Actuator will have as standard double travel stops that can be adjusted while the actuator is pressurized. Actuator shall have Delrin 500 piston bearings permanently affixed to the pistons, all seals on the end caps, and pinions shall be Buna N material. Actuator shall have the capability of being field converted from double acting to spring return type with no additional tooling required. The actuator shall have the same end-to-end dimensions for double acting as spring return. Spring design shall be of the fully encapsulated design for safety. All dimensions shall be to Namur for the affixing of accessories and transmitting devices. All mounting dimensions to the valve or damper shall be to ISO 5211 standard. All actuators shall be fully traceable by an individual serial number permanently stamped on the body. This actuator shall be designated as the UniTorq "M" Series actuator.

*For additional information regarding our products,
or to place an order, please phone our office.
UniTorq can also be reached via the web at*

www.untorq.com

Unitorq Actuators & Controls

2825 Pacific Drive • Norcross, Georgia 30071
Tel: 770.446.7074 • Fax: 770.447.1825