



Deaerators for Industrial Applications



newterra[™]
smart technology. sustainable solutions.[™]



Combined Cycle Power Plant – Deaera

Deaerator - a device that is widely used for the removal of oxygen and other dissolved gases from the feedwater to steam-generating boilers [dissolved oxygen in boiler feedwaters will cause corrosion damage in steam systems by attaching to the walls of metal piping and other metallic equipment and forming oxides (rust)].

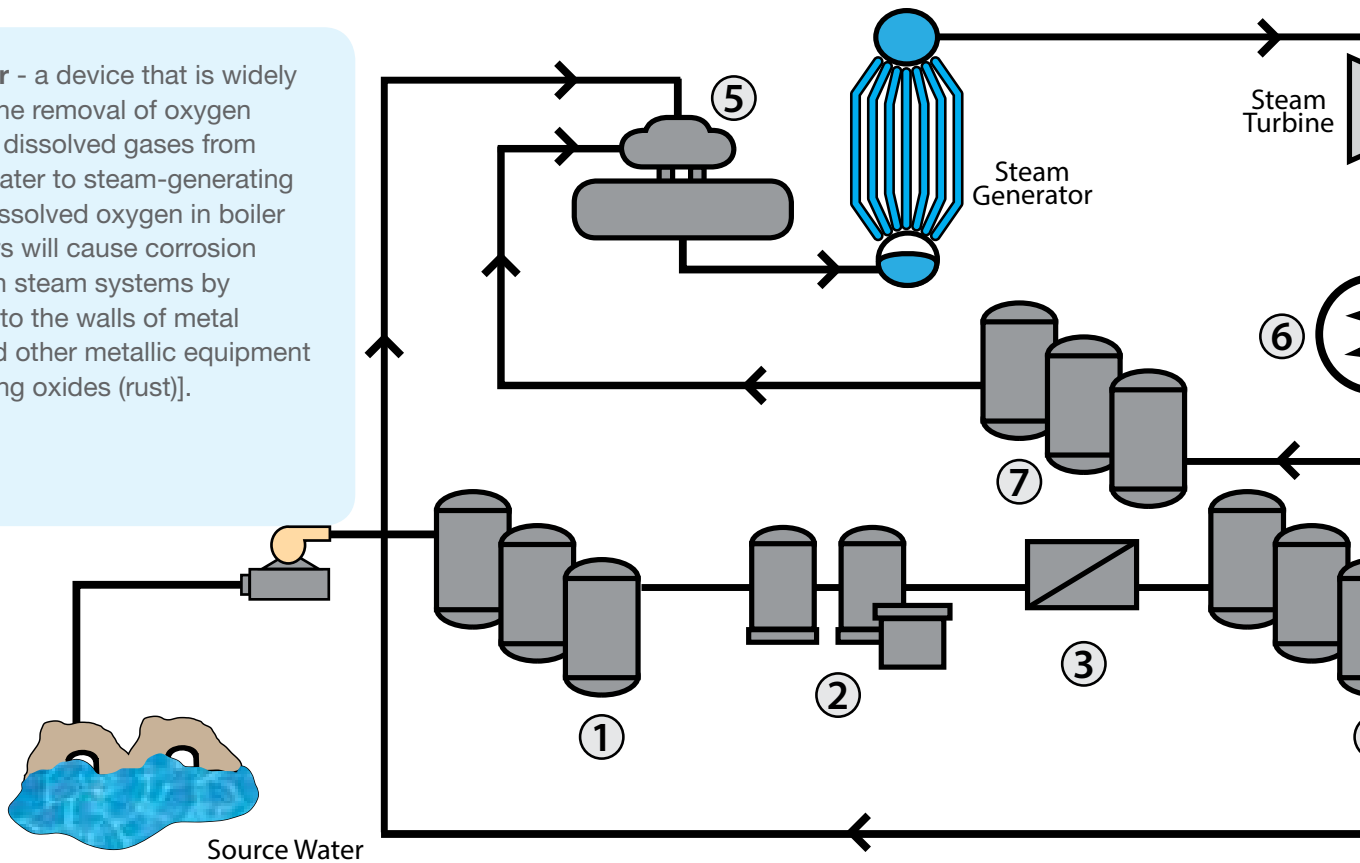

1. Boiler Make-up Water – Filtration

- Multimedia Filtration
- Screen Filtration
- Activated Carbon Filtration
- Iron Filtration
- Microfiltration/Ultrafiltration

2. Boiler Make-up Water – Softening

- Sodium Zeolite Softening
- Lime Softening
- Nanofiltration

3. Boiler Make-up Water – Filtration

- Dissolved Solids Reduction
- Nanofiltration
- Reverse Osmosis
- Demineralization

4. Boiler Make-up Water – Polishing

- Demineralization
- Electro-deionization

5. Deaeration

- Counterflow Deaeration – Spray/Tray
- Parallel Downflow Deaeration – Spray/Tray
- Atomizing Deaeration – Spray
- Vacuum Deaeration

6. Condenser Rebuilds

- Westinghouse Condenser Rebuilds

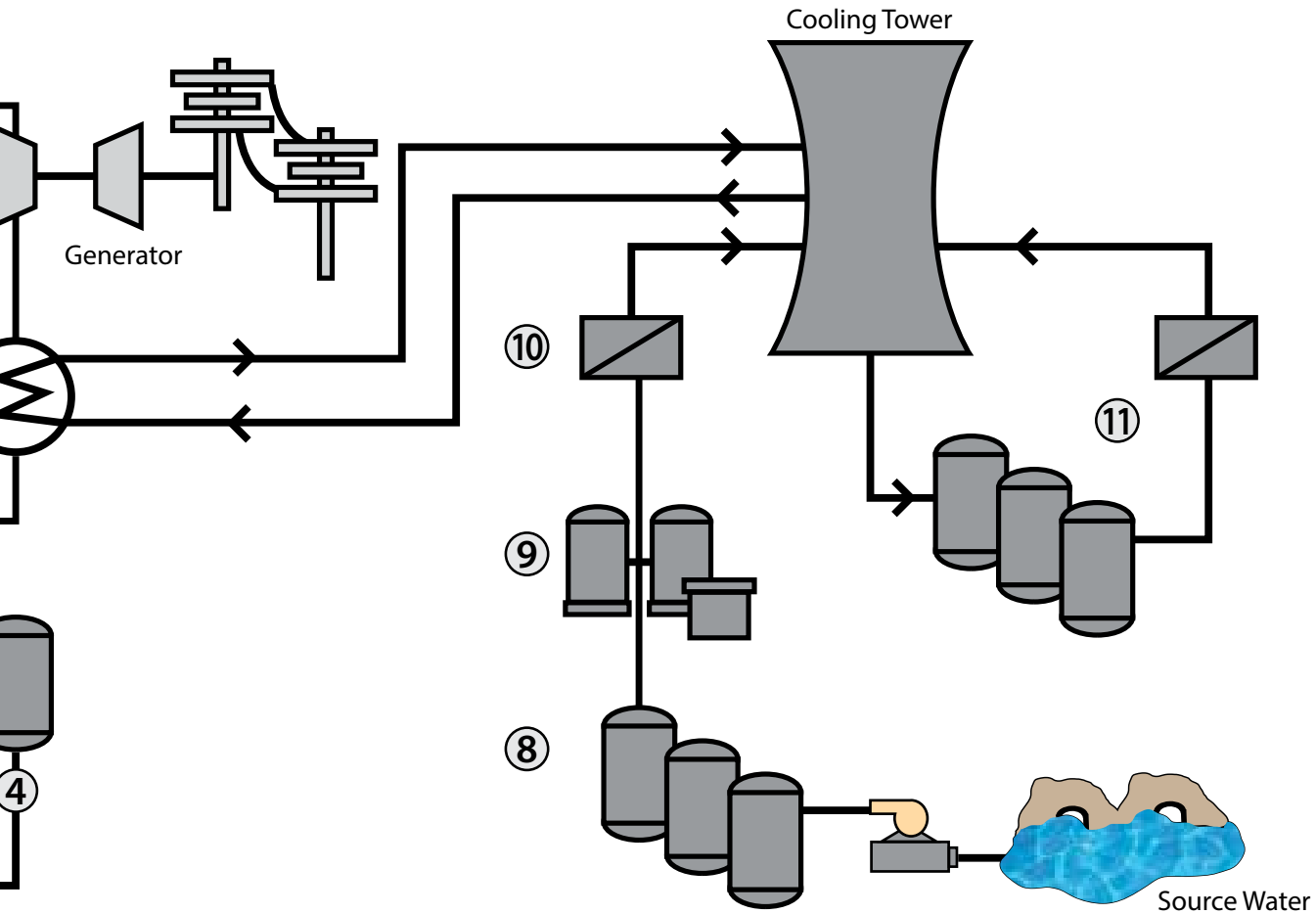

7. Condensate Recovery – Condensate Treatment
 Mix Bed Condensate Polishing
 Deep Bed Condensate Polishing

8. Cooling Tower Make-up Water – Filtration
 Multimedia Filtration
 Screen Filtration
 Iron Filtration
 Microfiltration/Ultrafiltration

9. Cooling Tower Make-up Water – Softening
 Sodium Zeolite Softening
 Nanofiltration

10. Cooling Tower Make-up Water – Filtration
 Nanofiltration
 Reverse Osmosis

11. Cooling Tower Water – Blowdown Recovery and Recycle
 Multimedia Filtration
 Screen Filtration
 Activated Carbon Filtration
 Microfiltration/Ultrafiltration
 Reverse Osmosis

NOTE: **newterra** also offers a full line of Butterfly, Gate, Globe, Check, and Ball Valves for: Steam Drums, Superheaters, Reheaters, Steam Turbines, Condensers, Water Loops, Heat Exchangers, Economizers, Flash Tanks, Evaporators, Scrubbers, Precipitators, Combustion Turbines, Fuel Storage and Distribution – www.industrial.newterra.com



Parallel Downflow

Construction

Trays: Type 430 SS, pan type, one piece

Water distributor: 316 Stn. Stl. Lock-N-Load® Spray Nozzles

Design pressure: As required

Deaerator top: Welded Steel Plate, ASME stamped

Storage tanks: Welded Steel Plate, ASME stamped

Vent condenser: Direct Contact Type with Stainless Steel baffling



Advantages

- Deaerator performs equally well between the extremes of 100% make-up water (below 50° F) and mostly hot condensate as well as substantial flashing returns
- Handles higher steam flows through the tray stack. Requires the lowest temperature differential of any deaerator to meet operating warranty; typically 20° F or less
- Water seal between trays and the spray section eliminates direct impingement of the spray on the trays and insures even distribution of the water over the tray stack
- Use of trays with less open area than required in counterflow operation maximizes spilling edge and exposes a greater surface of the water to the stripping action of the steam
- Optimized mixing plus higher steam velocity results in maximum gas removal efficiency
- Genuine two stage deaeration



Deaerating Trays

- One piece construction type 430 stainless steel. Easily handled by one person
- Trays are designed so that the pressure shell does not come in contact with the un-deaerated water or concentrated non-condensable gases
- Trays provide excellent performance having the highest spilling edge and baffling area available in any tray design, which allows for maximum water “break-up” and retention time

Principle of Operation

Water enters the preheating compartment and is heated to saturation temperature. Here, the bulk of the non-condensable gases is removed before the water enters the trays.

Heated water passes through the water seal type distributors to the tray section. The water seals prevent bypassing of steam into the preheating compartment and prevent non-condensable gases from entering the tray compartment from the preheating section. Water passes downward through the trays to complete final deaeration and then goes to storage. Steam enters at the inlet nozzle and passes through ports in the tray compartment to the space above the trays, flowing downward with the water through the tray section.

This action provides highly efficient distribution over the trays, maximizing surface contact between steam and water, and prevents damming up of water and possible water hammer. Practically no condensation of steam occurs in the tray compartment, since inlet water has been heated to within a few degrees of steam temperature in the preheater compartment. The entire volume of uncontaminated steam is employed in the scrubbing action, thus removing the final traces of oxygen.

Steam leaves the bottom of the trays, then flows to the preheater compartment where it is condensed. Non-condensable gases are discharged to the atmosphere.



Counterflow Deaerator

Construction

Trays: Type 430 SS, pan type, riveted construction

Water distributor: 316 Stn. Stl. Lock-N-Load® Spray Nozzles

Design pressure: As required

Deaerator top: Welded Steel Plate, ASME stamped

Storage tanks: Welded Steel Plate, ASME stamped

Vent condenser: Direct Contact Type with Stainless Steel baffling



Advantages

- Cost competitive for large capacity applications
- Highly reliable for attaining specified results over a varying load range
- Simplicity and rugged design offers cost savings for many applications, especially where a high percentage of condensate returns are introduced
- Easy access for spray nozzle inspection, even on smaller models
- Meets HEI requirements



Deaerating Trays

- Type 430 stainless steel, assembled with stainless steel rivets. Each tray assembly consists of eight or twelve tray channels arranged in two or three staggered tiers of four each, depending on application.

Principle of Operation

Incoming water flows through the spray nozzles and enters the vent condensing chamber as a thin-walled, hollow cone spray pattern. Latent heat transfer is instantaneous because of the intimate water-to-steam exposure.

As the water reaches the tray stack, its temperature is within 2° F of the saturated steam temperature, and virtually all dissolved oxygen and free carbon dioxide have been removed.

Nearly all of the steam has now condensed, permitting the non-condensable gases to be carried through the vent by the remaining steam, exiting as a plume.

The preheated water is distributed over the trays and flows down over staggered pans in the trays, making its way through pure steam flowing in the opposite direction. The water leaving the bottom layer of trays is fully deaerated.



Deaeration – Spray Atomizing Type

Construction

Deaerator top: Welded Steel Plate, ASME stamped

Storage tanks: Welded Steel Plate, ASME stamped

Water distributor: 316 Stn. Stl. Spray Nozzle

Vent condenser: Direct Contact with Stainless Steel baffling

Design pressure: As required

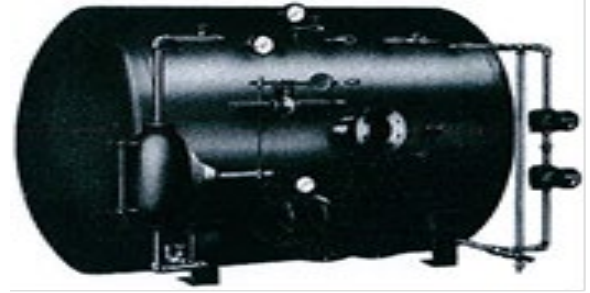

Advantages

- Controlled steam atmosphere
- Maximum effective contact between steam and water
- Variable orifice self-regulating atomizer assures maintenance of energy required and guaranteed performance at ALL rates of flow
- Compact, easily accessible design
- Minimum headroom requirements with horizontal design

The Spray Type Atomizing Method

- Atomizing Deaerators protect power plant boilers and piping where the operating pressure is steady and the temperature rise is greater than 50° F. The Cochrane® Atomizing Deaerator is particularly superior in the following applications:
- Marine – Providing guaranteed performance regardless of normal roll, pitch and list of the ship
- Handling low pH or acid waters
- Handling waters containing scale or solids due to absence of baffles or trays

Principle of Operation

The Cochrane® Atomizing Deaerator is a two-stage design. In the first stage, water is sprayed in direct contact with steam and heated practically to saturation temperature. At this stage the bulk of the non-condensable gases are liberated and all released gases are discharged from the unit. The preheated, partially deaerated water then passes to the second stage where it comes in contact with a constant high velocity steam jet for final deaeration. The steam jet is created by a variable orifice atomizing

valve which is self-compensating to changes in load or variation in operating conditions. The energy of the steam jet breaks up the water, producing a mist or fog of finely divided particles to assure maximum surface exposure to the scrubbing steam. Any remaining gas is removed and carried to the first stage by the steam, while the deaerated water falls to the storage section.



Deaeration – HRSG Applications

Deaeration In HRSG Service

- ASME section 1 pressure vessel construction
 - 100% radiography
 - Post weld heat treatment
 - No stainless to carbon pressure boundary welds, i.e. weld overlay nozzles required for water inlet and vent
- Deaerator integral to the steam drum therefore eliminating the need for a separate storage tank
- Integral deaerator will also reduce steam line piping required
- Utilizes the same sizing and deaerator selection criteria as shown previously

Parallel Downflow Deaerators

- Water seal is provided to ensure steam flow through the tray box
- Steam is piped from the steam drum, outside of the DA, and combined with the pegging steam line
- Higher loading capabilities allow for a smaller deaerator, reducing the footprint required
- Excels in high make-up water applications
- Perfect choice for HRSG applications due to its capability to handle abrupt starts/stops and wide load swings

Counter Flow Deaerators

- LP steam from the drum is piped directly into the bottom of the DA through a flanged connection
- Good for high condensate return units, especially 100% condensate return applications

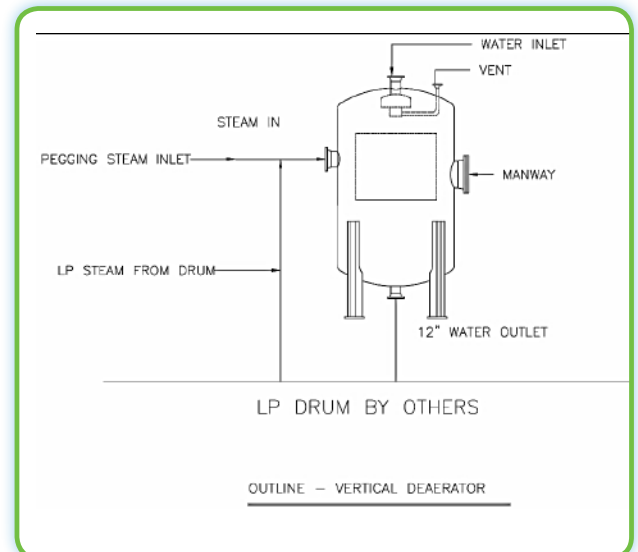
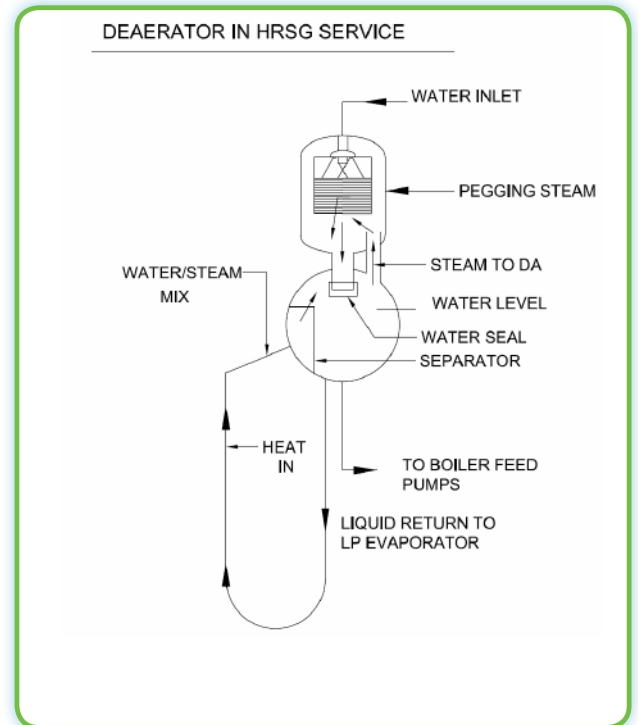



Deaeration – Solutions

Packaged Deaerators

- **newterra** offers packaged deaerators utilizing parallel downflow, counterflow or spray-atomizing to best suit every application. Capacity ranges from 10,000 lbs. per hour and larger. **newterra** packages deaerators with pump and control skids below in compact packages or on separate skids for large applications.
- Fully skidded compact packages
- Packages with off-skid deaerators for larger applications
- Low-Headroom spray-atomizing units available
- Start-up services available



Specifications (All Units)

- 7 ppb (0.005 cc/L) O₂ content
- 10 minute storage capacity standard
- Dual, vertical multistage pumps
- Control panel with motor starters and level alarm lights
- All accessories required to operate the system
- Custom accessories and options available

Vacuum Deaerators & Forced Draft Degassifiers

- **newterra** custom-engineers Vacuum Deaerators used to reduce or eliminate corrosion of piping systems, heat exchanger and process equipment by removing dissolved oxygen and carbon dioxide without steam feed or a need for raising water temperature. **newterra** also custom-engineers Forced Draft Degassifiers used to provide an economical and efficient method to remove dissolved gases, principally carbon dioxide and hydrogen sulfide.

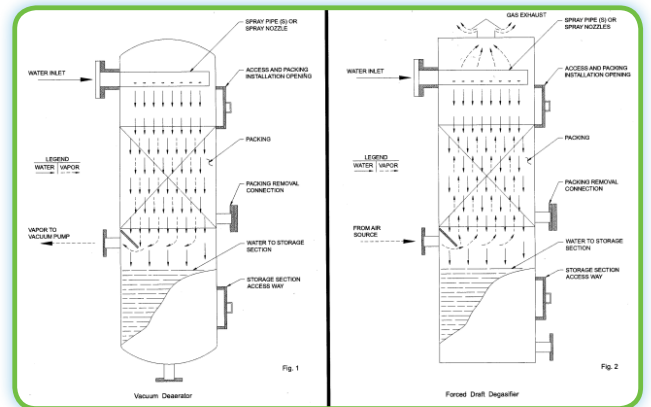



Innovation – Proprietary Spray Nozzle Design

Lock-N-Load® Spray Nozzle

- Polished type 316 stainless steel stem and hardware
- Non-binding Teflon guide
- Mounting hub reduces wear by eliminating lateral, high velocity water currents from impinging on the spring and stem in spray header configurations
- Rugged spring design constructed of Type 316 Stainless Steel
- Saves much time and money on inspection/replacement of nozzles
- Access hand holes on parallel down flow DA's allow for nozzle access without having to enter DA and remove trays
- Retrofit kits for existing DA's (most types and manufacturers)
- Patented under U.S. Patents 8,114,202 B2 & 8,359,746 B2

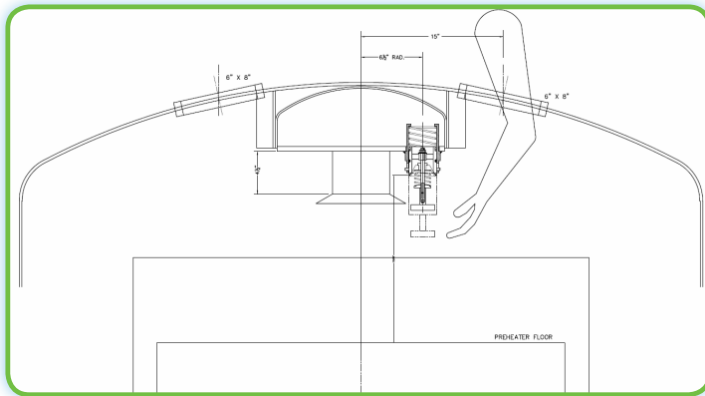

Lock-N-Load provides exceptional access for inspection on most deaerator models





Innovation – Proprietary Spray Nozzle Design

newterra ACCU-SPRAY®

- Polished stainless steel stem
- Non-Binding Teflon guide prevents tilting of the valve disc due to flow impingement
- Rugged stainless steel spring construction for max corrosion protection
- Retaining ring secures gasket preventing distortion and by-pass leakage
- Heavy spring retainers/supports with open design to minimize pressure loss
- Conical-shaped disc insures uniform spray pattern water break over all conditions of load

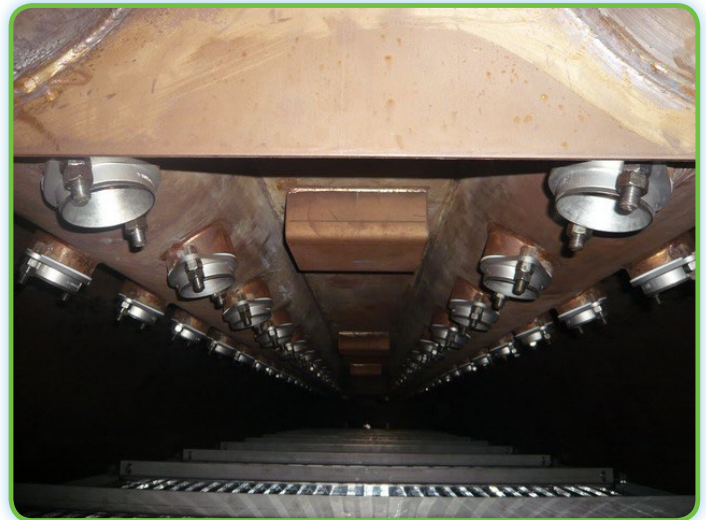

Accu-Spray installed in large horizontal parallel downflow deaerator



Selection – Which Deaerator is Best For Your Application?

Parallel Downflow

- Introduced 85 years ago
- Utilizes a two-stage cascade stripping process
- Unique Water Seal
- Co-current steam/water tray contact
- Versatility (100% make up or mixed condensate)
- Will perform equally under all operating conditions
- Ability to handle a high percentage of make-up water
- Ability to handle low temp waters
- Temp rise as low as 15° F
- High turndown capabilities
- Able to deaerate high pressure/flashing condensate returns
- More spilling edge and surface per unit volume of trays
- Greater level of agitation/control
- Inherent de-superheating ability

Counterflow

- Cost effective in larger applications and “utility type ” power plants
- Utilizes a counter flow stripping process
- Counter-current steam/water tray contact
- Operating conditions must be rigidly specified at design
- Best utilized when feed water contains a high percentage of make up water (>50%)
- Not suitable where water temperature falls below 60° F
- Minimum 30° F temperature rise
- Susceptible to tray flooding

Performance Guarantee

- All Cochrane and Chicago Heater brand **newterra** Deaerators are guaranteed to:
 - Deliver deaerated water with an oxygen content not exceeding 0.005 cc per liter (less than 7 parts per billion) – generally recognized as zero oxygen – at all rates of flow
 - Deliver water heated to full saturation temperature corresponding to the steam pressure maintained within the unit
 - Operate without undue noise, rumble or hammer

Certifications

- CRN
- ASTM
- NACE
- HEI DA Standard
- ASME





About newterra

A Global Water Technology Leader

newterra is recognized as a leader in the development of sustainable treatment solutions for water, sewage, wastewater and groundwater remediation for industrial, municipal, land development, commercial & residential markets. Our heritage of innovation in providing clean water solutions dates all the way back to 1863. Over that time, **newterra** has grown to over 250 people and we've installed thousands of treatment systems – some of which operate in the most extreme conditions on the planet.

Full Control from Start to Finish

At **newterra**, we take full control of virtually every aspect of the treatment systems we build – from process design and engineering to manufacturing, installation, operation and ongoing parts & service support. That also includes manufacturing our own MicroClear™ UF membranes and EPRO™ Reverse Osmosis (RO) systems in **newterra** owned facilities. This award-winning approach ensures **newterra** treatment systems meet our high standards for quality and on-time delivery.



MicroClear®

BELCO



WESTINGHOUSE CONDENSERS

COCHRANE

NEW-2105-I_D



newterra
smart technology. sustainable solutions.™

1.800.633.7435
industrial.newterra.com

1.800.420.4056
newterra.com